

10Gb/s SFP+ 1550nm Duplex 80Km Transceiver

RT-P10Z15-C(I)00

Product Features

- Up to 10Gb/s data links
- EML laser transmitter and APD photo-detector
- Up to 80Km transmission on SMF
- Hot-pluggable SFP+ footprint
- Duplex LC/UPC type pluggable optical interface
- Low power dissipation
- Metal enclosure, for lower EMI
- RoHS compliant and lead-free
- Single +3.3V power supply
- Support Digital Diagnostic Monitoring interface
- Compliant with SFF-8472
- Case operating temperature
Commercial: 0°C to +70°C
Industrial: -40°C to +85°C

Applications

- 10GBASE-ZR/EW Ethernet
- 80km 10G Fiber channel
- SONET OC-192/SDH STM-64

The SFP+ transceivers are high performance, cost effective modules supporting multi data-rate of 10Gbps and 80Km transmission distance with SMF. The transceivers are compatible with SFP+ Multi-Source Agreement (MSA) , For further information, please refer to SFP+ MSA.

Ordering Information

Part Number	Description
RT-P10Z15-C(I)00	10Gb/s SFP+ 1550nm Duplex 80Km Transceiver

For More Information:

Wuhan RayOptek Co.,Ltd
 Address: G3-201,New Energy Building,No.999 Gao Xin Road, Wuhan, Hubei, China
 Phone:0086-27-87106345 Fax: 0086-27-87106345 Email: sales@rayoptek.com

Pin Descriptions

Pin	Symbol	Name/Description	NOTE
1	VEET	Module transmitter ground	1
2	Fault	Module transmitter Fault	2
3	Disable	Transmitter Disable; Turns off transmitter laser output	3
4	SDL	2 wire serial interface data input/output (SDA)	4
5	SCL	2 wire serial interface clock input (SCL)	4
6	MOD-ABS	Module Absent, connect to VeeR or VeeT in the module	2
7	RS0	Rate select0: module inputs and are pulled low to VeeT with >30 kΩ resistors in the module.	
8	LOS	Receiver Loss of Signal Indication	
9	RS1	Rate select1: module inputs and are pulled low to VeeT with >30 kΩ resistors in the module.	
10	VeeR	Module receiver ground	1
11	VeeR	Module receiver ground	1
12	RD-	Receiver inverted data out put	
13	RD+	Receiver non-inverted data out put	
14	VeeR	Module receiver ground	1
15	VccR	Module receiver 3.3V supply	
16	VccT	Module transmitter 3.3V supply	
17	VeeT	Module transmitter ground	1
18	TD+	Transmitter non-inverted data out put	
19	TD-	Transmitter inverted data out put	
20	VeeT	Module transmitter ground	1

Notes:

1. The module ground pins shall be isolated from the module case.
2. This pin is an open collector/drain output pin and shall be pulled up with 4.7K-10Kohms to Host_Vcc on the host board.
3. This pin shall be pulled up with 4.7K-10Kohms to VccT in the module.
4. This pin is an open collector/drain output pin and shall be pulled up with 4.7K-10Kohms to Host_Vcc on the host board.

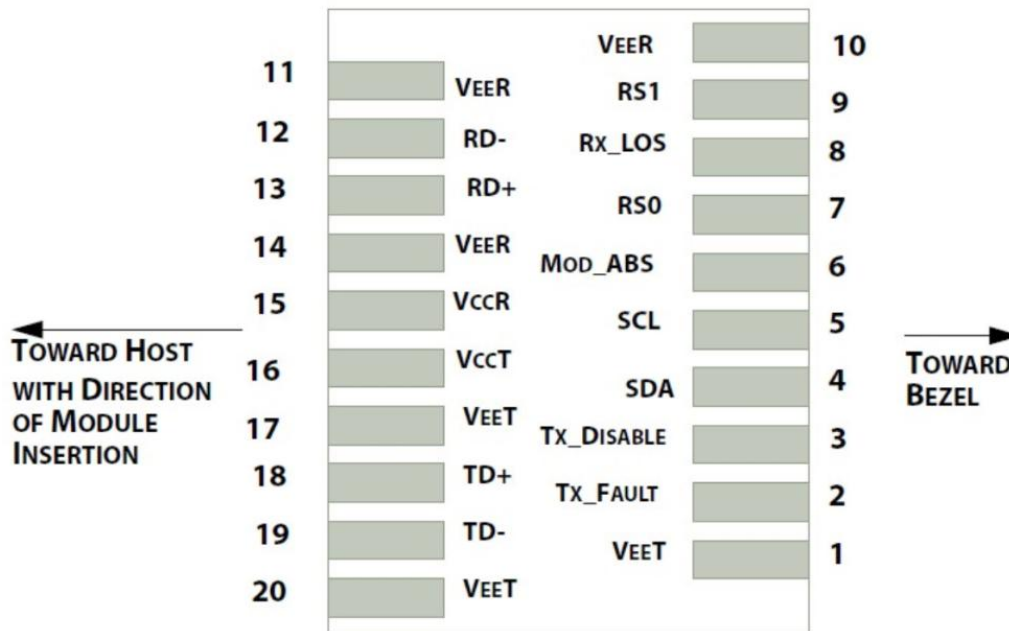

Pin out of Connector Block on Host Board

Absolute Maximum Ratings

Parameter	Symbol	Min.	Typ.	Max.	Unit	Note
Storage Temperature	Ts	-50		+95	°C	
Relative Humidity	RH	5		95	%	
Power Supply Voltage	VCC	-0.3		+4	V	

Recommended Operating Conditions

Parameter	Symbol	Min.	Typ.	Max.	Unit	Note
Case Operating Temperature	Tc	0		70	°C	Commercial
	Tl	-40		85	°C	Industrial
Power Supply Voltage	Vcc	3.14	3.3	3.47	V	
Power Supply Current	Icc			450	mA	
Data Rate	BR		10.31		Gbps	
9/125um G.652 SMF	Lmax			80	Km	

Electrical Characteristics

Parameter	Symbol	Min.	Typ.	Max.	Unit	Note
Transmitter						
Tx Disable Input-High	VDISH	2		V _{cc} +0.3	V	
Tx Disable Input-Low	VDISL	0		0.8	V	
Tx Fault Input-High	VTxFH	2		V _{cc} +0.3	V	
Tx Fault Input-Low	VTxFL	0		0.8	V	
Receiver						
LOSS -High	V _{LOSH}	2		V _{cc} +0.3	V	
LOSS -Low	V _{LOSL}	0		0.8	V	

Optical Characteristics

Parameter	Symbol	Min.	Typ.	Max.	Unit	Note
Transmitter						
Average Output Power	POUT	0		5	dBm	
Extinction Ratio	ER	8.2			dB	
Center Wavelength	λ_c	1530	1550	1570	nm	EML Laser
Side Mode Suppression Ratio	SMSR	30			dB	
Transmitter OFF Output Power	P _{off}			-30	dBm	
Receiver						
Receiver Sensitivity	SENS			-24	dBm	1
Receiver Overload		-7			dBm	
Input Optical Wavelength	λ_C	1260		1620	nm	
LOS De-assert	LOSD			-25	dBm	
LOS Assert	LOSA	-35			dBm	2
LOS Hysteresis		0.5		5	dB	

Note:

1. Launched power (avg.) is power coupled into a single mode fiber with master connector. (Before of Life)
2. Measured with conformance test signal for BER = 10⁻¹².@10.3125Gbps, PRBS=2³¹-1,NRZ

EEPROM Information

EEPROM memory map specific data field description is as below:

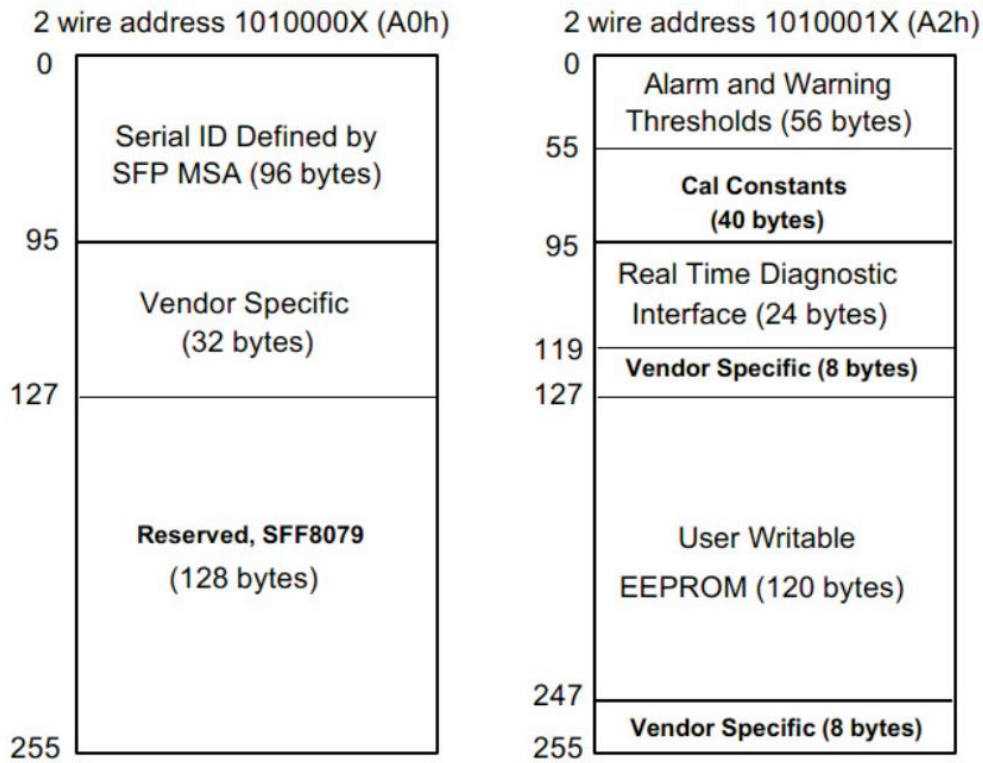

Digital Diagnostic Monitoring Interface

Five transceiver parameter values are monitored. The following table defines the monitored parameter's accuracy.

Parameter	Range	Accuracy	Calibration
Temperature	0 to +70°C (C)	±3°C	Internal
	-40 to +85°C (I)		
Voltage	2.97 to 3.63V	±3%	Internal
Bias Current	0 to 100mA	±10%	Internal
TX Power	-1 to 6dBm	±3dBm	Internal
RX Power	-25 to -6dBm	±3dBm	Internal

Recommend Circuit Schematic

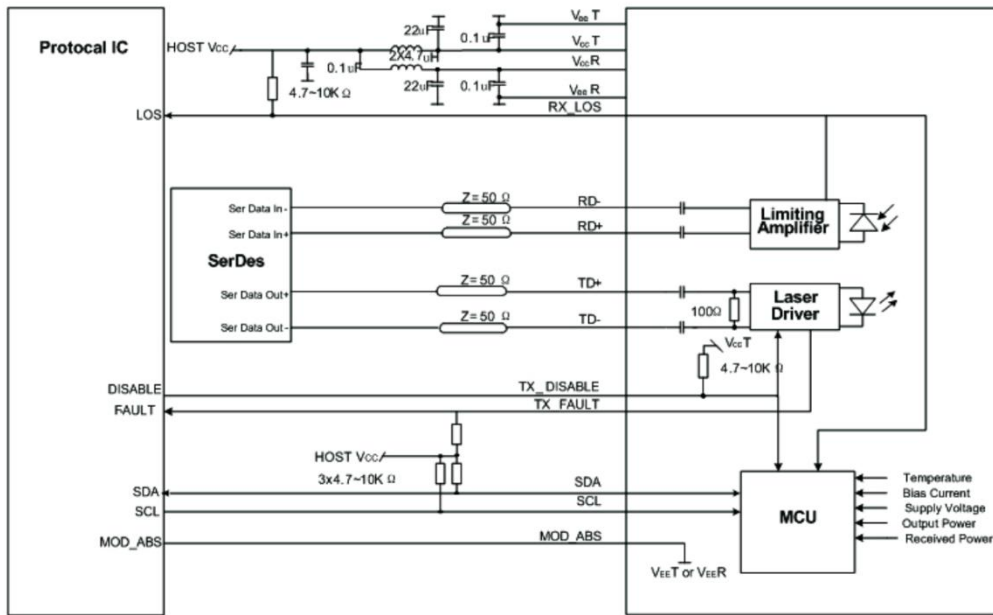

Mechanical Specifications

