

100G QSFP28 SR4 100m Optical Transceiver

Product Features

QSFP28 Serial Optical Interface

- High quality and reliability optical device and Sub-assemblies
- 4 VCSEL Lasers and 4 channels PIN photo detectors
- Maximum link length of 70m on OM3 MMF or 100m on OM4 MMF

QSFP28 MSA Compliant

- Compliant with SFF-8679 for electrical interface
- Compliant with SFF-8661 for mechanical interface
- QSFP28 Mechanical Interface for easy removal
- MPO Receptacle
- Compliant with SFF-8636 for 2-wire interface for management and DDM

Low Power Consumption

- Less than 2.5W in temperature range of 0 to 70°C

Applications

- 100G SR4 Ethernet links
- Data center
- Other high speed data connections

1. General Description

RT-MA0S85-C00 is a Four-Channel, Pluggable, Fiber-Optic QSFP28 SR4 for 100Gigabit Ethernet and Infiniband EDR applications. This transceiver is a high performance module for data communication and interconnect applications. It integrates four data lanes in each direction with 103.1Gbps bandwidth. The length of QSFP28 SR4 is up to 70 meters over OM3 MMF or 100 meters over OM4 MMF. This module is designed to operate over multimode fiber systems using a nominal wavelength of 850nm.

2. Functional Description

RT-MA0S85-C00 contains a MPO connector for the optical interface and a 38-pin connector for the electrical interface.

Transmitter Operation

The module converts 4 input channels of 25Gb/s electrical data to 4 channels optical signals and then transmit them with MPO connector for 100Gb/s optical transmission.

Receiver Operation

The module receive a 100Gb/s optical input into 4 channels of 850nm optical signals and then converts them to 4 output channels of 25Gb/s electrical data.

Management Interface

A 2-wire interface (SCL, SDA) is used for serial ID, digital diagnostics and other control and monitor functions.

Ordering Information

Part Number	Description
RT-MA0S85-C00	100G QSFP28 SR4 100m Optical Transceiver

For More Information:

Wuhan Rayoptek Co.,Ltd
 Address: G3-201,New Energy Building,No.999 Gao Xin Road, Wuhan, Hubei, China
 Phone:0086-27-87106345 Fax: 0086-27-87106345 Email: sales@rayoptek.com

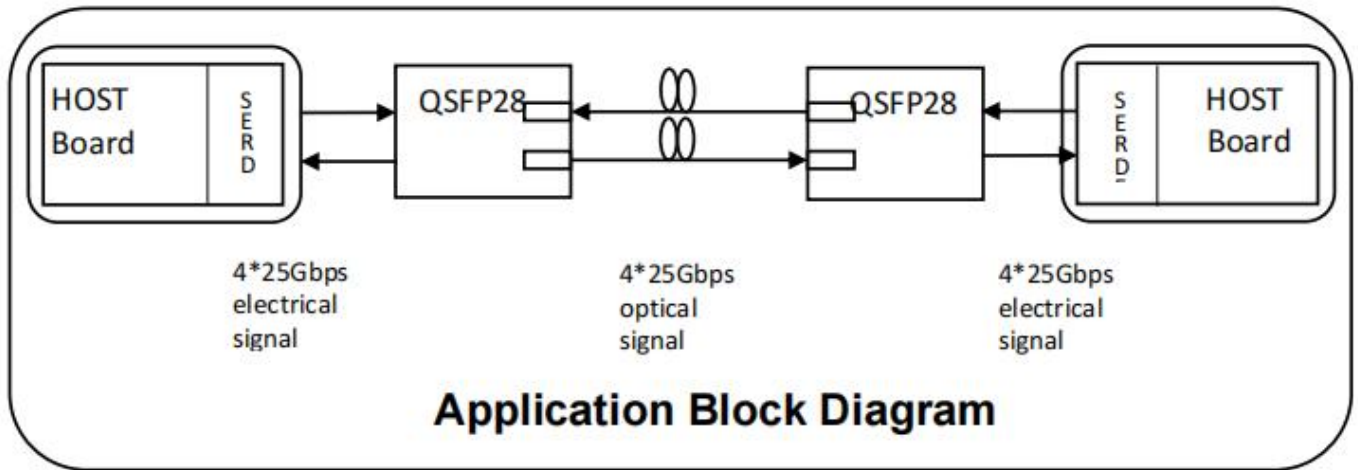

3. Absolute Maximum Ratings and Recommended Operating Conditions

Table 3.1 Absolute Maximum Ratings

Parameter	Symbol	Min	Max	Unit
Storage Temperature	Ts	-40	85	°C
Case Operating Temperature	Top	0	70	°C
Relative Humidity (non-condensation)	RH	5	95	%
Supply Voltage	Vcc	-0.5	3.6	V
Input Voltage	Vin	-0.5	VCC+0.5	V

Table 3.2 Recommended Operating Conditions

Parameter	Symbol	Min	Max	Unit
Operating Case Temperature	Top	0	70	°C
Relative Humidity(non-condensing)	RH	5	85	%
Power Supply Voltage	Vcc	3.135	3.465	V
Total Power Consumption	Pc	-	2.5	W

4. Optical Specification

4.1 Optical Transmitter

Table 4.1 Transmitter Optical Interface

Parameter	Symbol	Min	Typical	Max	Unit
Center Wavelength	λ_c	840	850	860	nm
Data rate per lane	DR		25.78125		Gbps
Average Launch Power	Pavg	-8.4		2.4	dBm
Optical Power OMA, each Lane	POMA	-6.4		3	
Extinction ratio	ER	2			dB
Spectral Width , RMS				0.6	nm

Optical Return Loss Tolerance	ORLT			12	dB
Optical Power for TX DISABLE				-30	dBm

4.2 Optical Receiver

Table 4.2 Receiver Optical Interface

Parameter	Symbol	Min	Typical	Max	Unit
Center Wavelength		840	850	860	nm
Signaling Speed	DR		25.78125		Gbps
Overload input optical power	λ_c	2.4			dBm
Stressed receiver sensitivity (OMA), each lane(5E-5)				-5.2	dBm
Rx LOS	Assert		-30		dBm
	De-assert			-9	dBm
	Hysteresis		0.5		dB

5. Electrical Specification

Table 5.1 High speed Electrical Specifications

Parameters	Min	Typical	Max	Unit
Supply voltage	3.135		3.465	V
Supply current			750	mA
Input differential impedance	90	100	110	Ω
Differential data input swing	300		1100	mVpp
Differential data output swing	300		850	mVpp
Input Logic Level High	2		Vcc	V
Input Logic Level Low	0		0.8	V
Output Logic Level High	Vcc-0.5		Vcc	V
Output Logic Level Low	0		0.4	V

Table 5.2 2-wire Electrical Specifications

Parameter	Symbol	Min	Max	Unit
Host 2-wire Vcc voltage	Vcc_Host_2w	3.14	3.46	V
SCL and SDA Voltage ^[1]	VOL	0.0	0.40	V
	VOH	Vcc_Host_2w - 0.5	Vcc_Host_2w + 0.3	V
	VIL	-0.3	VccT*0.3	V
	VIH	VccT*0.7	VccT+0.5	V

6. User Interface

6.1 Management Interface

QSFP28 2-Wire Serial Interface Protocol

QSFP28 2-wire serial interface is specified in the SFF-8636. The QSFP28 2-wire serial interface is used for serial ID, digital diagnostics, and certain control functions. The 2-wire serial interface is mandatory for all QSFP28 modules.

QSFP28 Management Interface

The common memory map for managed external cable interfaces is utilized for serial ID, digital monitoring and control functions. The map is arranged into a single lower page address space of 128 bytes and multiple upper address pages.

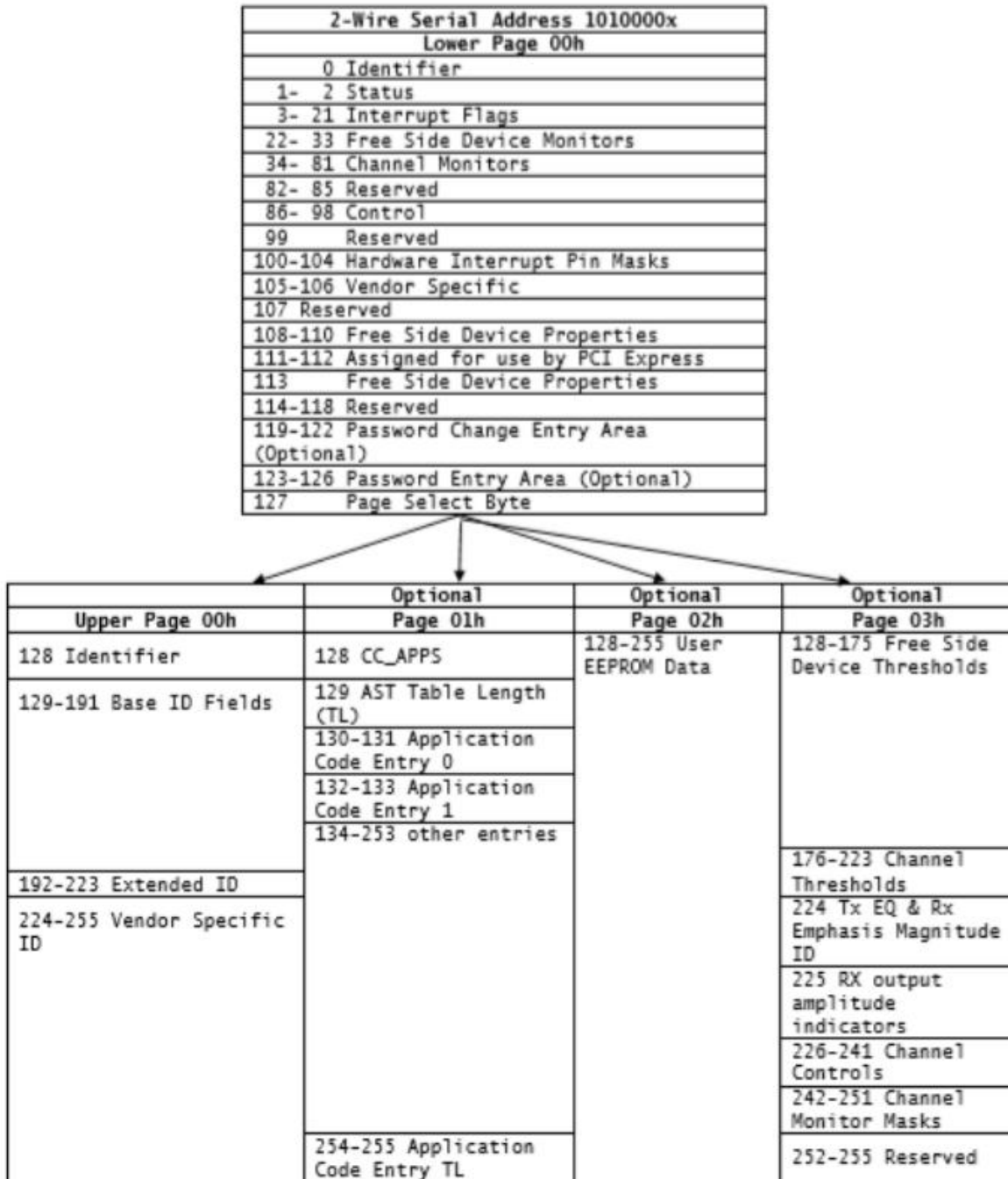

Figure 6.1 QSFP28 Memory Map

6.2 Memory Map in detail

Byte Address	Description	Type
0	Identifier (1 Byte)	Read Only
1-2	Status (2 Bytes)	Read Only
3-21	Interrupt Flags (31 Bytes)	Read Only
22-33	Module Monitors (12 Bytes)	Read Only
34-81	Channel Monitors (48 Bytes)	Read Only
82-85	Reserved (4 Bytes)	Read Only
86-97	Control (12 Bytes)	Read/Write
98-99	Reserved (2 Bytes)	Read/Write
100-106	Module and Channel Masks (7 Bytes)	Read/Write
107-118	Reserved (12 Bytes)	Read/Write
119-122	Reserved (4 Bytes)	Read/Write
123-126	Reserved (4 Bytes)	Read/Write
127	Page Select Byte	Read/Write

Figure6.2 Low Page 00H Memory Map

Byte Address	Description	Type
128-175	Module Thresholds (48 Bytes)	Read Only
176-223	Reserved (48 Bytes)	Read Only
224-225	Reserved (2 Bytes)	Read Only
226-239	Reserved (14 Bytes)	Read/Write
240-241	Channel Controls (2 Bytes)	Read/Write
242-253	Reserved (12 Bytes)	Read/Write
254-255	Reserved (2 Bytes)	Read/Write

Figure6.3 Upper Page 03H Memory Map

This structure permits timely access to addresses in the lower page such as interrupt flags and monitors. Less time critical entries such as serial ID information and threshold settings are available with the page select function. Data used for interrupt handling is located in Lower Page 00h to enable single block read operations for time critical data.

Upper Page 01h and Upper Page 02h are optional. Upper Page 01h allows implementation of application select table while Upper Page 02h provides a user read/write space.

Implementation of these two pages is optional. Lower and Upper Page 00h are always implemented. Page 03h is required if Page 00h Byte 2 bit 2 is low. Pages 20-7Fh are reserved for future use. Writing the value of a non-supported page shall not be accepted by the transceiver. The Page Select byte shall revert to 0 and read/write operations shall be to Upper Page 00h. Pages 04-1Fh and 80-FFh are for vendor specific functions.

Page02 is user EEPROM and its format dedicated by user. The detail description of low memory and Page00.Page03 upper memory please see SFF-8636 document.

Address	Name	Description
128	Identifier (1 Byte)	Identifier Type of serial transceiver
129	Ext. Identifier (1 Byte)	Extended identifier of serial transceiver
130	Connector (1 Byte)	Code for connector type
131-138	Transceiver (8 Bytes)	Code for electronic compatibility or optical compatibility
139	Encoding (1 Byte)	Code for serial encoding algorithm
140	BR, nominal (1 Byte)	Nominal bit rate, units of 100 Mbits/s
141	Extended RateSelect Compliance (1 Byte)	Tags for Extended RateSelect compliance
142	Length SMF (1 Byte)	Link length supported for SM fiber in km
143	Length E-50 μm (1 Byte)	Link length supported for EBW 50/125 μm fiber, units of 2 m
144	Length 50 μm (1 Byte)	Link length supported for 50/125 μm fiber, units of 1 m
145	Length 62.5 μm (1 Byte)	Link length supported for 62.5/125 μm fiber, units of 1 m
146	Length copper (1 Byte)	Link length supported for copper, units of 1 m
147	Device Tech (1 Byte)	Device technology
148-163	Vendor name (16 Bytes)	QSFP vendor name (ASCII)
164	Extended Transceiver (1 Byte)	Extended Transceiver Codes for InfiniBand [†]
165-167	Vendor OUI (3 Bytes)	QSFP vendor IEEE vendor company ID
168-183	Vendor PN (16 Bytes)	Part number provided by QSFP vendor (ASCII)
184-185	Vendor rev (2 Bytes)	Revision level for part number provided by vendor (ASCII)
186-187	Wavelength (2 Bytes)	Nominal laser wavelength (Wavelength = value / 20 in nm)
188-189	Wavelength Tolerance (2 Bytes)	Guaranteed range of laser wavelength (+/- value) from Nominal wavelength (Wavelength Tol. = value / 200 in nm)
190	Max Case Temp (1 Byte)	Maximum Case Temperature in Degrees C
191	CC_BASE (1 Byte)	Check code for Base ID fields (addresses 128-190)
192-195	Options (4 Bytes)	Rate Select, TX Disable, TX Fault, LOS
196-211	Vendor SN (16 Bytes)	Serial number provided by vendor (ASCII)
212-219	Date code (8 Bytes)	Vendor's manufacturing date code
220	Diagnostic Monitoring Type (1 Byte)	Indicates which type of diagnostic monitoring is implemented
221	Enhanced Options (1 Byte)	Indicates which optional enhanced features are implemented
222	Reserved (1 Byte)	Reserved
223	CC_EXT	Check code for the Extended ID Fields (addresses 192-222)
224-255	Vendor Specific (32 Bytes)	Vendor Specific EEPROM

Figure6.4 Upper page 00H Memory Map

6.3 Digital Diagnostic Monitor Accuracy

The following characteristics are defined over recommended operating conditions.

Table 6.3.1 Digital Diagnostic Monitor Accuracy

Parameter	Accuracy	Unit
Internally measured transceiver temperature	+/-3	°C
Internally measured transceiver supply voltage	+/-3	%
Measured Tx bias current	+/-10	%
Measured Tx output power	+/-3	dB
Measured Rx received average optical power	+/-3	dB

7. Pin Assignment and Description

QSFP28 Transceiver Pad Layout, host PCB QSFP28 Pinout, and PIN Descriptions are as follows :

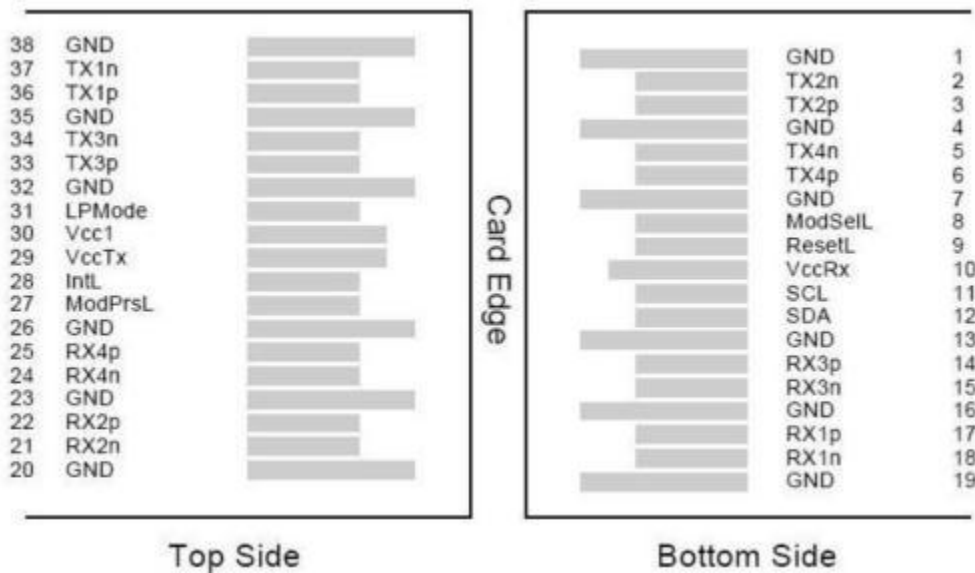

Figure 7.1 QSFP28 Transceiver Electrical Pad Pinout

Table 8.1 Pin Description

Pin#	Name	Logic	Description	Power Seq.	Note
1	GND		Ground	1st	1
2	Tx2n	CML-I	Transmitter Inverted Data Input	3rd	
3	Tx2p	CML-I	Transmitter Non-Inverted Data output	3rd	
4	GND		Ground	1st	1
5	Tx4n	CML-I	Transmitter Inverted Data Input	3rd	
6	Tx4p	CML-I	Transmitter Non-Inverted Data output	3rd	
7	GND		Ground	1st	1
8	ModSelL	LVTLL-I	Module Select	3rd	

9	ResetL	LVTTLL-I	Module Reset	3rd	
10	VccRx		+3.3V Power Supply Receiver	2nd	2
11	SCL	LVCNOS- I/O	2-Wire Serial Interface Clock	3rd	
12	SDA	LVCNOS- I/O	2-Wire Serial Interface Data	3rd	
13	GND		Ground	1st	1
14	Rx3p	CML-O	Receiver Non-Inverted Data Output	3rd	
15	Rx3n	CML-O	Receiver Inverted Data Output	3rd	
16	GND		Ground	1st	1
17	Rx1p	CML-O	Receiver Non-Inverted Data Output	3rd	
18	Rx1n	CML-O	Receiver Inverted Data Output	3rd	
19	GND		Ground	1st	1
20	GND		Ground	1st	1
21	Rx2n	CML-O	Receiver Inverted Data Output	3rd	
22	Rx2p	CML-O	Receiver Non-Inverted Data Output	3rd	
23	GND		Ground	1st	1
24	Rx4n	CML-O	Receiver Inverted Data Output	3rd	
25	Rx4p	CML-O	Receiver Non-Inverted Data Output	3rd	
26	GND		Ground	1st	1
27	ModPrsL	LVTTTL-O	Module Present	3rd	
28	IntL	LVTTTL-O	Interrupt	3rd	
29	VccTx		+3.3 V Power Supply transmitter	2nd	2
30	Vcc1		+3.3 V Power Supply	2nd	2
31	LPMode	LVTTTL-I	Low Power Mode	3rd	
32	GND		Ground	1st	1
33	Tx3p	CML-I	Transmitter Non-Inverted Data Input	3rd	
34	Tx3n	CML-I	Transmitter Inverted Data Output	3rd	
35	GND		Ground	1st	1
36	Tx1p	CML-I	Transmitter Non-Inverted Data Input	3rd	
37	Tx1n	CML-I	Transmitter Inverted Data Output	3rd	
38	GND		Ground	1st	1

Notes:

1. GND is the symbol for signal and supply (power) common for the QSFP28 module. All are common within the QSFP28 module and all module voltages are referenced to this potential unless otherwise noted. Connect these directly to the host board signal-common ground plane.

2. Vcc Rx, Vcc1 and Vcc Tx are the receiver and transmitter power supplies and shall be applied concurrently. Vcc Rx, Vcc1 and Vcc Tx may be internally connected within the QSFP28 transceiver module in any combination. The connector pins are each rated for a maximum current of 500 mA.

8. Mechanical Dimensions

Figure 8.1 shows the package dimensions of the module. The module is designed to be compliant with QSFP28 MSA specification. Package dimensions are specified in SFF-8661.

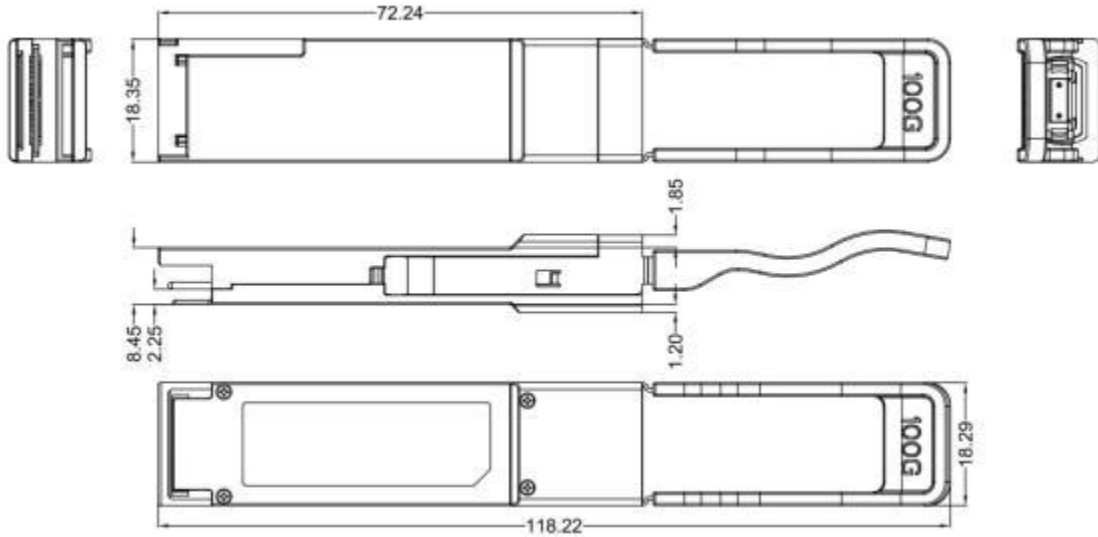

Figure 8.1 Package dimensions

9. Ordering Information

Part Number	Temperature Range	Distance	Fiber Type	E/O	O/E
RT-MA0S85-C00	0 to 70°C	100m	MMF	VCSEL 850nm	PIN