

RT-QA0GCM-C00

100Gb/s QSFP28 CWDM4 10km Optical Transceiver

Product Features

- Four-channel full-duplex transceiver modules
- Transmission data rate up to 26Gbit/s per channel
- Up to 10km transmission of single mode fiber
- Low power consumption <3.5W
- Operating case temperature 0°C to +70°C
- 3.3V power supply voltage
- RoHS 6 compliant
- Hot Pluggable QSFP form factor
- LC connector receptacle
- Built-in digital diagnostic function

Applications

- 100G Ethernet
- Proprietary High Speed Interconnections
- Datacenter
- 100G CWDM4 application with FEC

The Rayoptek RT-QA0GCM-C00 is a Four-Channel, Pluggable, dual LC, Fiber-Optic QSFP28 Transceiver for 100G Ethernet applications. The QSFP28 full-duplex optical module offers 4 independent transmit and receive channels, each capable of 26Gbps operation for an aggregate data rate of 104Gbps 10km using single mode fiber. These modules are designed to operate over single mode fiber systems using 1271nm-1331nm DFB laser array. QSFP28 CWDM4 is one kind of transceiver which provides increased port density and total system cost savings. They are compliant with the QSFP28 MSA, CWDM4 MSA and portions of IEEE P802.3bm.

Ordering Information

Part Number	Description
RT-QA0GCM-C00	QSFP28 CWDM4 10km optical transceiver with full real-time digital diagnostic monitoring and pull tab

For More Information:

Wuhan RayOptek Co., Ltd
 Address: G3-201, New Energy Building, No.999 Gao Xin Road, Wuhan, Hubei, China
 Phone: 0086-27-87106345 Fax: 0086-27-87106345 Email: sales@rayoptek.com

Regulatory Compliance

Feature	Standard	Performance
Electromagnetic Interference (EMI)	FCC Part 15 Class B EN 55022:2010, Class B	Compatible with standards
Electromagnetic susceptibility (EMS)	EN 55024:2010	Compatible with standards
Laser Eye Safety	FDA 21CFR 1040.10 and 1040.11 EN60950, EN (IEC) 60825-1,2	Compatible with Class I laser product

Absolute Maximum Ratings

The operation in excess of any absolute maximum ratings might cause permanent damage to this module.

Parameter	Symbol	Min	Max	Unit	Notes
Storage Temperature	T _S	-40	85	°C	
Operating Case Temperature	T _{OP}	0	70	°C	
Supply Voltage	V _{CC}	-0.5	3.6	V	
Input Voltage	V _{in}	-0.5	V _{CC} +0.3	V	
Relative Humidity (non-condensation)	RH	0	85	%	

Recommended Operating Conditions and Power Supply Requirements

Parameter	Symbol	Min	Typical	Max	Unit	Notes
Operating Case Temperature	T _{OP}	0		70	°C	
Power Supply Voltage	V _{CC}	3.135	3.3	3.465	V	
Data Rate, each Lane	DR		25.78125		Gb/s	
Power Consumption				3.5	W	
Data Speed Tolerance	ΔDR	-100		+100	ppm	
Link Distance with G.652	D	0		10	km	

Electrical Characteristics

The following electrical characteristics are defined over the Recommended Operating Environment unless otherwise specified.

Parameter	Symbol	Min	Typical	Max	Unit	Notes
Differential input impedance	Z _{in}	90	100	110	ohm	
Differential input impedance	Z _{out}	90	100	110	ohm	
Differential input voltage amplitude	ΔV _{in}	300		1100	mVp-p	
Differential output voltage amplitude	ΔV _{out}	500		800	mVp-p	
Input Logic Level High	V _{IH}	2.0		V _{CC}	V	
Input Logic Level Low	V _{IL}	0		0.7	V	
Output Logic Level High	V _{OH}	V _{CC} -0.5		V _{CC}	V	
Output Logic Level Low	V _{OL}	0		0.4	V	

Optical Characteristics

Parameter	Symbol	Min	Typical	Max	Unit	Notes
Wavelength Assignment	L0	1264.5	1271	1277.5	nm	
	L1	1284.5	1291	1297.5	nm	
	L2	1304.5	1311	1317.5	nm	
	L3	1324.5	1331	1337.5	nm	
Transmitter						
RMS Spectral Width	λ _{rms}			3.5	nm	1
Average Launch Power, each lane	PAVG	-6.5		2.5	dBm	
Optical Modulation Amplitude (OMA)	POMA	-4		2.5	dBm	1
Difference in Launch Power between any two lanes	P _{tx,diff}			4.0	dB	
Transmitter and Dispersion Penalty per Lane	TDP			3	dBm	

Rise/Fall Time	Tr/Tf			30	ps	
Extinction Ratio	ER	3.5			dB	
Transmitter Reflectance	RT			-12	dB	
Transmitter Eye Mask Margin	EMM	10			%	2
Average Launch Power OFF Transmitter, each Lane	Poff			-30	dBm	
Transmitter Eye Mask Definition {X1, X2, X3, Y1, Y2, Y3}		{0.31, 0.4, 0.45, 0.34, 0.38, 0.4}				
Receiver						
Damage Threshold	THd	3.5			dBm	
Overload, each lane	OVL	2.5			dBm	
Receiver Sensitivity in OMA, each Lane	SEN			-11.5	dBm	3
Signal Loss Assert Threshold	LOSA	-24		-13.6	dBm	
Signal Loss Deassert Threshold	LOSD			-11.6	dBm	
LOS Hysteresis	LOSH		1.5		dB	
Optical Return Loss	ORL			-12	dBm	

Notes:

1. Transmitter wavelength, RMS spectral width and power need to meet the OMA minus TDP specs to guarantee link performance.
2. The eye diagram is tested with 1000 waveform.
3. Sensitivity is specified at 5x10-5 BER.

Block Diagram of Transceiver

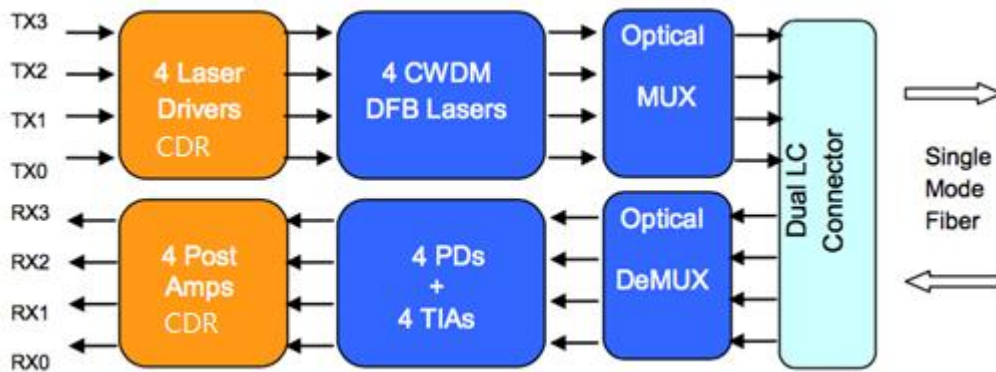

Recommended Power Supply Filter

The host board should use the power supply filtering shown as below.

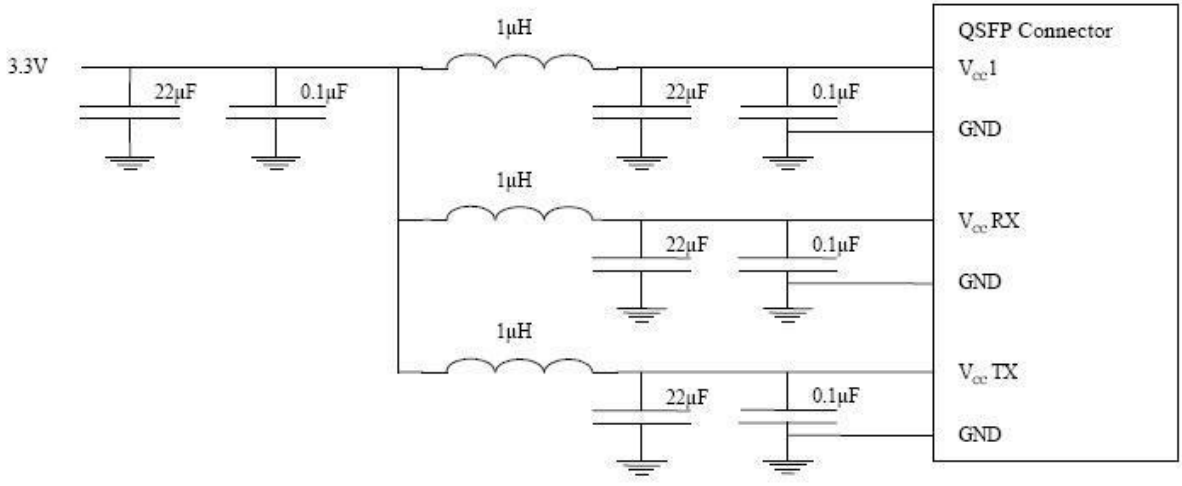

Host Board Power Supply Filtering

Mechanical Dimensions

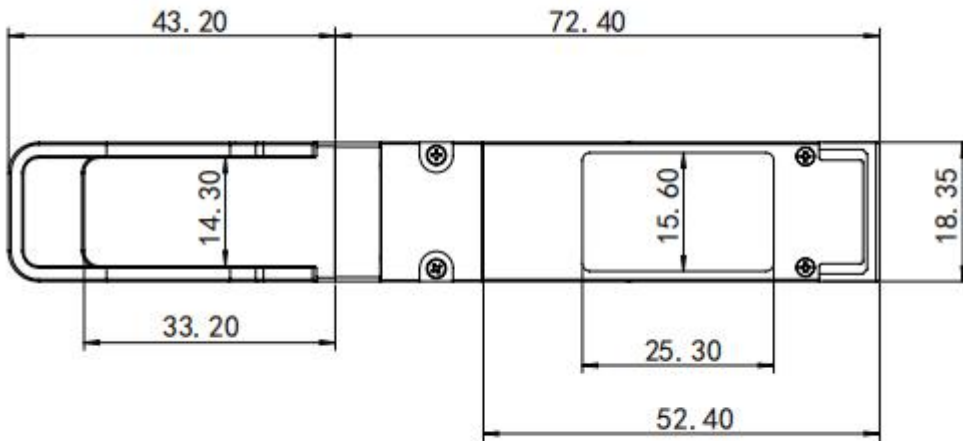

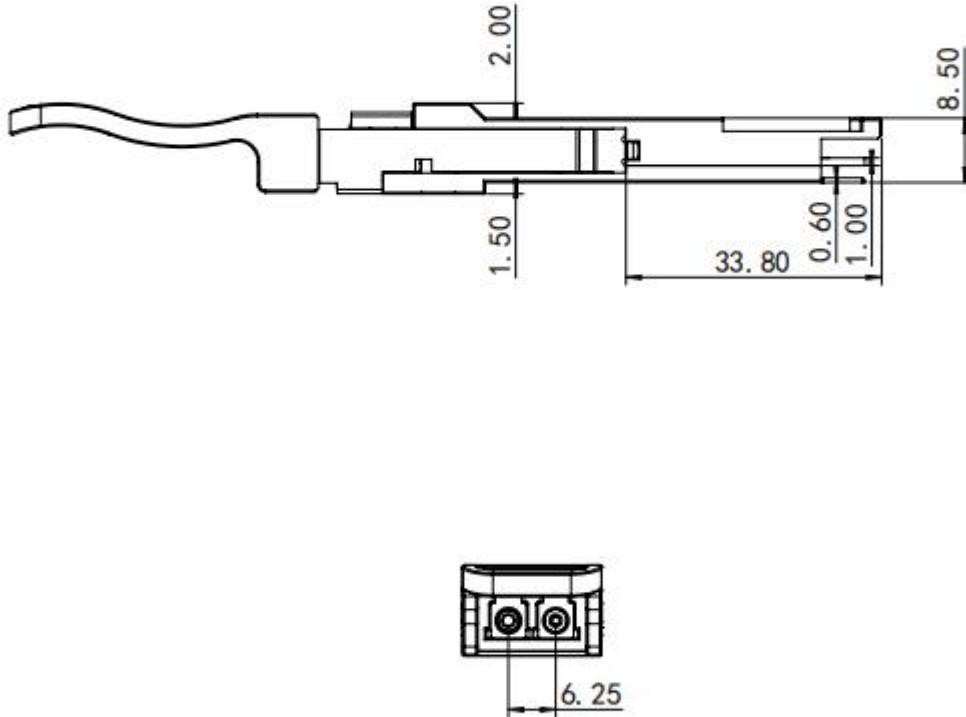

ESD

This transceiver is specified as ESD threshold 1kV for SFI pins and 2kV for all other electrical input pins, tested per MIL-STD-883, Method 3015.4 /JESD22-A114-A (HBM). However, normal ESD precautions are still required during the handling of this module. This transceiver is shipped in ESD protective packaging. It should be removed from the packaging and handled only in an ESD protected environment.

Laser Safety

This is a Class 1 Laser Product according to IEC 60825-1:2007. This product complies with 21 CFR 1040.10 and 1040.11 except for deviations pursuant to Laser Notice No. 50, dated (June 24, 2007).

Digital Diagnostic Functions

The following digital diagnostic characteristics are defined over the normal operating conditions unless otherwise specified.

Parameter	Symbol	Min	Max	Unit	Notes
Temperature monitor absolute error	DMI_Temp	-3	+3	°C	Over operating temperature range
Supply voltage monitor absolute error	DMI_VCC	-0.1	+0.1	V	Over full operating range
Channel RX power monitor absolute error	DMI_RX_Ch	-3	3	dB	
Channel Bias current monitor	DMI_Ibias_Ch	-10%	+10%	mA	

Channel TX power monitor absolute error	DMI_TX_Ch	-3	3	dB	
---	-----------	----	---	----	--

Pin Assignment and Description

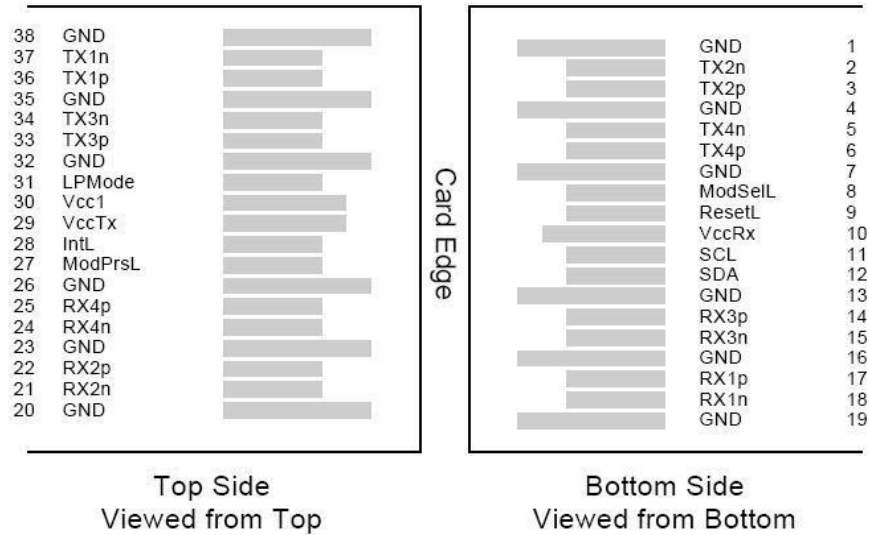

Pin Assignment

PIN #	Logic	Symbol	Description	Notes
1		GND	Ground	1
2	CML-I	Tx2n	Transmitter Inverted Data Input	
3	CML-I	Tx2p	Transmitter Non-Inverted Data output	
4		GND	Ground	1
5	CML-I	Tx4n	Transmitter Inverted Data Input	
6	CML-I	Tx4p	Transmitter Non-Inverted Data output	
7		GND	Ground	1
8	LVTLL-I	ModSelL	Module Select	
9	LVTLL-I	ResetL	Module Reset	
10		VccRx	+3.3V Power Supply Receiver	2
11	LVC MOS-I/O	SCL	2-Wire Serial Interface Clock	
12	LVC MOS-I/O	SDA	2-Wire Serial Interface Data	
13		GND	Ground	
14	CML-O	Rx3p	Receiver Non-Inverted Data Output	
15	CML-O	Rx3n	Receiver Inverted Data Output	
16		GND	Ground	1
17	CML-O	Rx1p	Receiver Non-Inverted Data Output	
18	CML-O	Rx1n	Receiver Inverted Data Output	

19		GND	Ground	1
20		GND	Ground	1
21	CML-O	Rx2n	Receiver Inverted Data Output	
22	CML-O	Rx2p	Receiver Non-Inverted Data Output	
23		GND	Ground	1
24	CML-O	Rx4n	Receiver Inverted Data Output	1
25	CML-O	Rx4p	Receiver Non-Inverted Data Output	
26		GND	Ground	1
27	LVTTL-O	ModPrsL	Module Present	
28	LVTTL-O	IntL	Interrupt	
29		VccTx	+3.3 V Power Supply transmitter	2
30		Vcc1	+3.3 V Power Supply	2
31	LVTTL-I	LPMODE	Low Power Mode	
32		GND	Ground	1
33	CML-I	Tx3p	Transmitter Non-Inverted Data Input	
34	CML-I	Tx3n	Transmitter Inverted Data Output	
35		GND	Ground	1
36	CML-I	Tx1p	Transmitter Non-Inverted Data Input	
37	CML-I	Tx1n	Transmitter Inverted Data Output	
38		GND	Ground	1

Notes:

1.GND is the symbol for signal and supply (power) common for QSFP+ modules. All are common within the QSFP+ module and all module voltages are referenced to this potential unless otherwise noted. Connect these directly to the host board signal common ground plane.

2. VccRx, Vcc1 and VccTx are the receiving and transmission power suppliers and shall be applied concurrently. Recommended host board power supply filtering is shown in Figure 3 below. Vcc Rx, Vcc1 and VccTx may be internally connected within the QSFP+ transceiver module in any combination. The connector pins are each rated for a maximum current of 500mA.

Contact Information**Wuhan RayOptek CO.,Ltd**

Headquarter

📍 Address:G3-201, New Energy Building, No.999 Gao Xin Road, Wuhan, Hubei, China

☎ Tel:+86-27-87106345

✉ Email:sales@rayoptek.com