

## RT-PAZL13-C(I)00

### SFP28 25Gb/s LR 10km DDMI

<p><b>Product Features</b></p> <ul style="list-style-type: none"> <li>• Supports 25.78Gb/s aggregate bit rate</li> <li>• 1310nm DFB Laser transmitter and PIN/TIA receiver</li> <li>• Maximum link length of 10km on Single Mode Fiber (SMF)</li> <li>• Hot-pluggable SFP28 footprint</li> <li>• Duplex LC receptacles</li> <li>• Single 3.3V power supply</li> <li>• Maximum power dissipation &lt; 1.2W</li> <li>• RoHS-6 compliant and lead-free</li> <li>• I2C management interface</li> <li>• Case operating temperature                     <ul style="list-style-type: none"> <li>Commercial: 0°C to +70°C</li> <li>Industrial: -40°C to +85°C</li> </ul> </li> </ul> <p><b>Applications</b></p> <ul style="list-style-type: none"> <li>• 25GBASE-LR 25G Ethernet</li> <li>• CPRI 10</li> </ul> <p><b>Compliance</b></p> <ul style="list-style-type: none"> <li>• SFP MSA.</li> <li>• IEEE802.3cc</li> <li>• SFF-8472</li> <li>• RoHS</li> </ul>	<p><b>Ordering Information</b></p> <table border="1"> <thead> <tr> <th>Part Number</th> <th>Description</th> </tr> </thead> <tbody> <tr> <td>RT-PAZL13-C(I)00</td> <td>SFP28 25Gb/s LR 10km DDMI</td> </tr> </tbody> </table> <p><b>For More Information:</b>                      Wuhan RayOptekCo.,Ltd                      Address: G3-201,NewEnergy Building,No.999 Gao Xin Road, Wuhan, Hubei, China                      Phone:0086-27-87106345                      Fax: 0086-27-87106345 Email: sales@rayoptek.com</p>	Part Number	Description	RT-PAZL13-C(I)00	SFP28 25Gb/s LR 10km DDMI
Part Number	Description				
RT-PAZL13-C(I)00	SFP28 25Gb/s LR 10km DDMI				

**Ordering information**

Part No.	Bit Rate (Gbps)	Laser (nm)	Distance	Fiber Type	DDMI	Connector	Temp
RT-PAZL13-C00	25.78125	1310	10km	SMF	YES	LC	0°C~+70°C
RT-PAZL13-I00	25.78125	1310	10km	SMF	YES	LC	-40°C~+85°C

## Pin Diagram

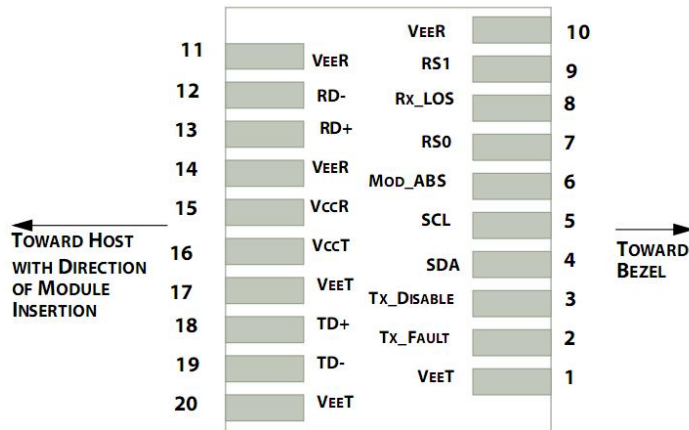

Pin out of Connector Block on Host Board

## Pin Descriptions

Pin	Symbol	Name/Description	Ref.
1	$V_{EET}$	Transmitter Ground (Common with Receiver Ground)	1
2	$T_{FAULT}$	Transmitter Fault.	2
3	$T_{DIS}$	Transmitter Disable. Laser output disabled on high or open.	3
4	SDA	2-wire Serial Interface Data Line	4
5	SCL	2-wire Serial Interface Clock Line	4
6	MOD_ABS	Module Absent. Grounded within the module	4
7	RS0	No connection required	
8	LOS	Loss of Signal indication. Logic "0" indicates normal operation.	5
9	RS1	No connection required	
10	$V_{EER}$	Receiver Ground (Common with Transmitter Ground)	1
11	$V_{EER}$	Receiver Ground (Common with Transmitter Ground)	1
12	RD-	Receiver Inverted DATA out. AC Coupled	
13	RD+	Receiver Non-inverted DATA out. AC Coupled	
14	$V_{EER}$	Receiver Ground (Common with Transmitter Ground)	1
15	$V_{CCR}$	Receiver Power Supply	
16	$V_{CCT}$	Transmitter Power Supply	
17	$V_{EET}$	Transmitter Ground (Common with Receiver Ground)	1
18	TD+	Transmitter Non-Inverted DATA in. AC Coupled.	
19	TD-	Transmitter Inverted DATA in. AC Coupled.	
20	$V_{EET}$	Transmitter Ground (Common with Receiver Ground)	1

Notes:

1. Circuit ground is internally isolated from chassis ground.
  2. TFAULT is an open collector/drain output, which is pulled up with a 4.7kΩ – 10kΩ resistor on the host board, but is grounded inside the SFP+ cable plug.
  3. Laser output disabled on TDIS >2.0V or open, enabled on TDIS <0.8V.
  4. Should be pulled up with 4.7kΩ – 10kΩ on host board to a voltage between 2.0V and 3.6V. MOD\_ABS pulls line low to indicate module is plugged in.
  5. LOS is open collector output. Should be pulled up with 4.7kΩ – 10kΩ on host board to a voltage between 2.0V and 3.6V.
- Logic 0 indicates normal operation; logic 1 indicates loss of signal.

### Absolute Maximum Ratings

Parameter	Symbol	Min.	Typ.	Max.	Unit	Ref.
Maximum Supply Voltage	Vcc	-0.5		3.6	V	
Storage Temperature	TS	-40		85	°C	
Relative Humidity	RH	0		85	%	

### Optical Characteristics

Parameter	Symbol	Min.	Typ.	Max.	Unit	Remark
<b>Transmitter</b>						
Signaling rate(range)	Sr		25.7825±100ppm		GBd	
Center Wavelength	λc	1295	1310	1325	nm	
Spectral Width(-20dB)	Pm			1	nm	
Average Output Power	Pavg	-7		2	dBm	
Extinction Ratio	ER	3.5			dB	
Side Mode Suppression Ratio	SMSR	30			dB	
Transmitter OFF Output Power	POff			-30	dBm	
Transmitter eye mask definition {X1, X2, X3, Y1, Y2, Y3} Hit ratio 5×10 <sup>-5</sup> hits per sample.			{0.31, 0.4, 0.45, 0.34, 0.38, 0.4}			
<b>Receiver</b>						
Signaling rate(range)	Sr		25.7825±100ppm		GBd	
Center Wavelength	λc	1295	1310	1325	nm	
Receiver Sensitivity(OMA)				-12	dBm	1
Receiver Reflectance	Rfl			-26	dBm	
Loss of Signal Assert	PA	-30			dBm	
Loss of Signal De-assert	PD			-13	dBm	
LOS Hysteresis	PD- PA	0.5			dB	

Note:

1. Hit ratio 5x10<sup>-5</sup>.

## Digital Diagnostic Memory Map

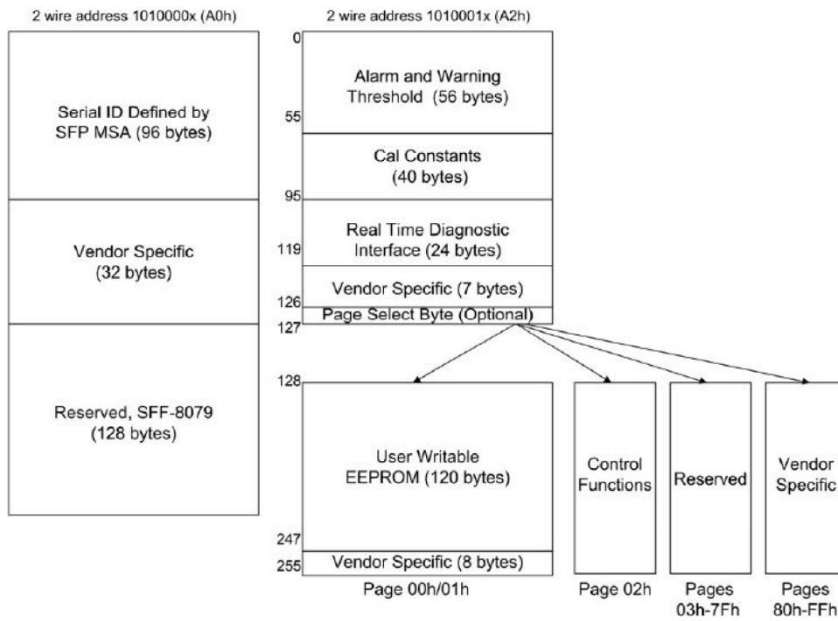

## Digital Diagnostic Specifications

Parameter	Unit	Accuracy
Case Temperature	°C	±3
Supply Voltage	V	±3%
Tx Bias Current	mA	±10%
Tx Optical Power	dB	±3
Rx Optical Power	dB	±3

## Electrical Interface Characteristics

Parameter	Symbol	Min	Type	Max	Unit	Ref.
Supply Voltage	Vcc	3.135	3.3	3.465	V	
Supply Current	Icc			300	mA	Commercial
				360	mA	Industrial
<b>Transmitter</b>						
Input differential impedance	Rin		100			1
Differential data input swing	Vin, pp	100		800	mV	

Transmit Disable Voltage	$V_D$	2		$V_{CC}$	V	
Transmit Enable Voltage	$V_{EN}$	Vee		Vee+0.8	V	
<b>Receiver</b>						
Differential data output swing	$V_{out, pp}$	100		800	mV	2
LOS Fault	$V_{LOS\_fault}$	2		$V_{ccHOST}$	V	3
LOS Normal	$V_{LOS\_norm}$	Vee		Vee+0.8	V	3

Notes:

1. Connected directly to TX data input pins.AC coupling from pins into laser driver IC.
2. Into 100Ω differential termination.
3. LOS is an open collector output. Should be pulled up with 4.7kΩ – 10kΩ on the host board. Normal operation is logic 0; loss of signal is logic 1. Maximum pull-up voltage is 5.5V.

Recommended Interface Circuit

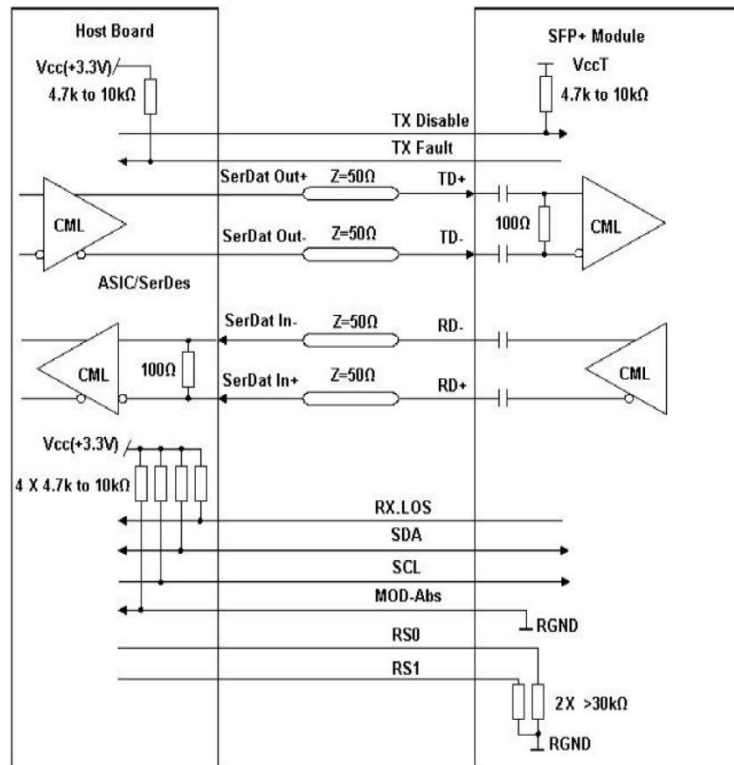

Mechanical Specifications (Unit: mm)

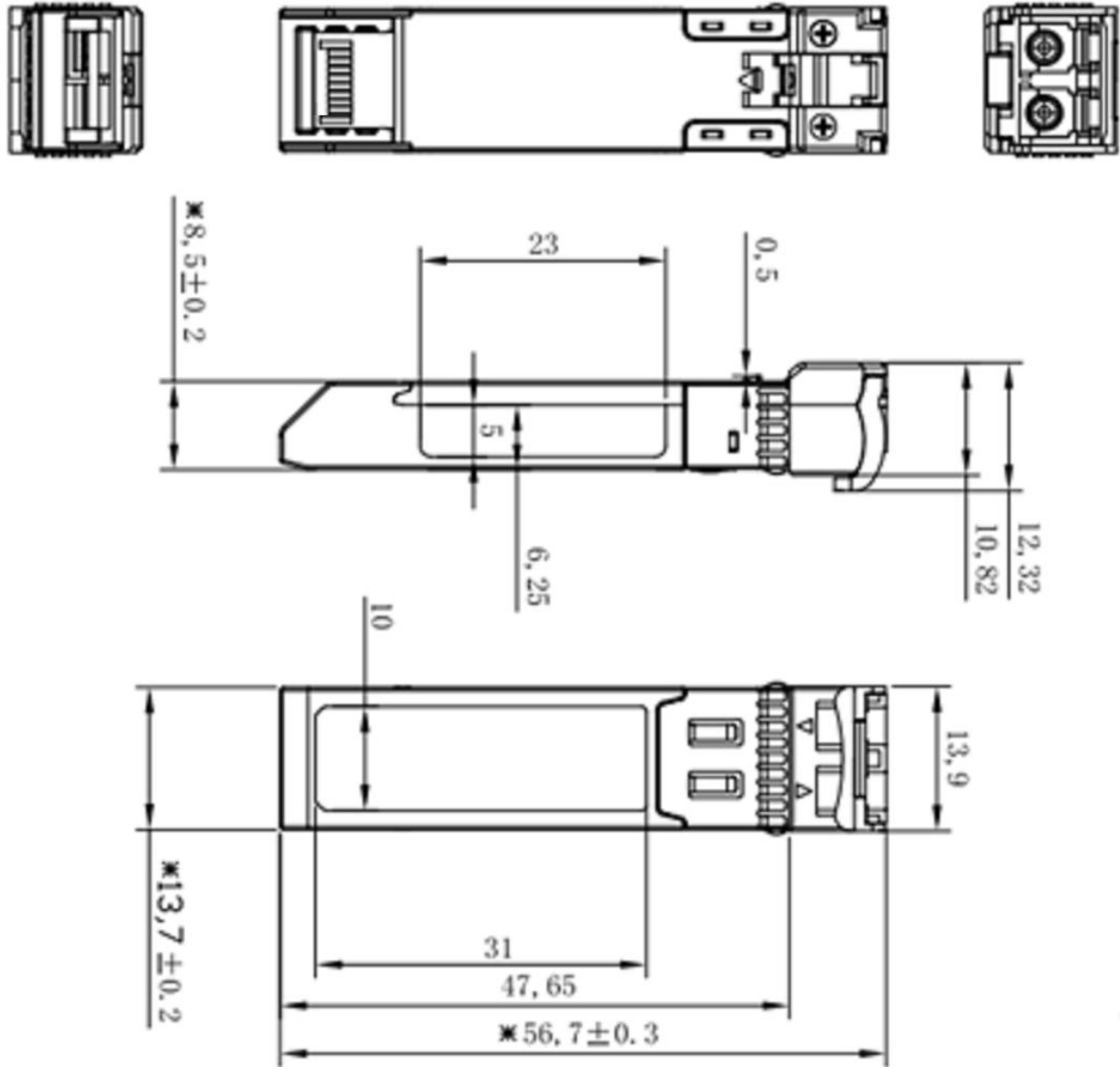

RT-PAZL13-C(I)00

## Contact Information

### Wuhan RayOptekCO.,Ltd

---

Headquarter

- 📍 Address:G3-201, New Energy Building, No.999 Gao Xin Road, Wuhan, Hubei, China
  - ☎ Tel:+86-27-87106345
  - ✉ Email:sales@rayoptek.com
-