

RT-AAZLXX-C(I)00

SFP28 25Gb/s BIDI 10km DDMI

Product Features

- Supports 25.78Gb/s aggregate bit rate
- 1270nm DFB Laser and PIN/TIA receiver for ESJMLB23-K10C(I)
- 1330nm DFB Laser and PIN/TIA receiver for ESJMLB32-K10C(I)
- Maximum link length of 10km on Single Mode Fiber (SMF)
- Hot-pluggable SFP28 footprint
- LC receptacles
- Single 3.3V power supply
- Maximum power dissipation < 1.2W
- RoHS-6 compliant and lead-free
- I2C management interface
- Case operating temperature
 - Commercial: 0°C to +70°C
 - Industrial: -40°C to +85°C

Applications

- 25GBASE-LR 25G Ethernet
- CPRI 10

Compliance

- SFP MSA.
- IEEE802.3cc
- SFF-8472
- RoHS

Ordering Information

Part Number	Description
RT-AAZLXX-C(I)00	SFP28 25Gb/s BIDI 10km DDMI

For More Information:

Wuhan RayOptekCo.,Ltd
 Address: G3-201,NewEnergy Building,No.999 Gao Xin Road, Wuhan, Hubei, China
 Phone:0086-27-87106345
 Fax: 0086-27-87106345 Email: sales@rayoptek.com

Ordering information

Part No.	Bit Rate (Gbps)	Laser (nm)	Distance	Fiber Type	DDMI	Connector	Temp
RT-AAZLC3-C00	25.78125	1270	10km	SMF	YES	LC	0°C~+70°C
RT-AAZL3C-C00	25.78125	1330	10km	SMF	YES	LC	0°C~+70°C
RT-AAZLC3-I00	25.78125	1270	10km	SMF	YES	LC	-40°C~+85°C
RT-AAZL3C-I00	25.78125	1330	10km	SMF	YES	LC	-40°C~+85°C

Pin Diagram

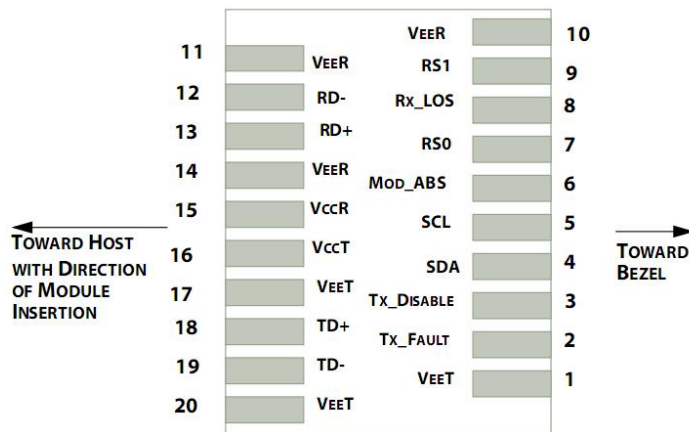

Pin out of Connector Block on Host Board

Pin Descriptions

Pin	Symbol	Name/Description	Ref.
1	V_{EET}	Transmitter Ground (Common with Receiver Ground)	1
2	T_{FAULT}	Transmitter Fault.	2
3	T_{DIS}	Transmitter Disable. Laser output disabled on high or open.	3
4	SDA	2-wire Serial Interface Data Line	4
5	SCL	2-wire Serial Interface Clock Line	4
6	MOD_ABS	Module Absent. Grounded within the module	4
7	RS0	No connection required	
8	LOS	Loss of Signal indication. Logic "0" indicates normal operation.	5
9	RS1	No connection required	
10	V_{EER}	Receiver Ground (Common with Transmitter Ground)	1
11	V_{EER}	Receiver Ground (Common with Transmitter Ground)	1
12	RD-	Receiver Inverted DATA out. AC Coupled	
13	RD+	Receiver Non-inverted DATA out. AC Coupled	
14	V_{EER}	Receiver Ground (Common with Transmitter Ground)	1

15	V_{CCR}	Receiver Power Supply	
16	V_{CCT}	Transmitter Power Supply	
17	V_{EET}	Transmitter Ground (Common with Receiver Ground)	1
18	TD+	Transmitter Non-Inverted DATA in. AC Coupled.	
19	TD-	Transmitter Inverted DATA in. AC Coupled.	
20	V_{EET}	Transmitter Ground (Common with Receiver Ground)	1

Notes:

1. Circuit ground is internally isolated from chassis ground.
2. TFAULT is an open collector/drain output, which is pulled up with a 4.7kΩ – 10kΩ resistor on the host board, but is grounded inside the SFP+ cable plug.
3. Laser output disabled on TDIS >2.0V or open, enabled on TDIS <0.8V.
4. Should be pulled up with 4.7kΩ – 10kΩ on host board to a voltage between 2.0V and 3.6V. MOD_ABS pulls line low to indicate module is plugged in.
5. LOS is open collector output. Should be pulled up with 4.7kΩ – 10kΩ on host board to a voltage between 2.0V and 3.6V. Logic 0 indicates normal operation; logic 1 indicates loss of signal.

Absolute Maximum Ratings

Parameter	Symbol	Min.	Typ.	Max.	Unit	Ref.
Maximum Supply Voltage	Vcc	-0.5		3.6	V	
Storage Temperature	TS	-40		85	°C	
Relative Humidity	RH	0		85	%	

Optical Characteristics

Parameter	Symbol	Min.	Typ.	Max.	Unit	Remark
Transmitter						
Signaling rate(range)	Sr		25.7825±100ppm		GBd	
Center Wavelength	λ_c	1260	1270	1280	nm	RT-AAZLC3-C(I)00
		1320	1330	1340	nm	RT-AAZL3C-C(I)00
Spectral Width(-20dB)	Pm			1	nm	
Average Output Power	Pavg	-2		4	dBm	
Extinction Ratio	ER	3.5			dB	
Side Mode Suppression Ratio	SMSR	30			dB	
Transmitter OFF Output Power	POff			-30	dBm	
Transmitter eye mask definition {X1, X2, X3, Y1, Y2, Y3} Hit ratio 5×10 ⁻⁵ hits per sample.			{0.31, 0.4, 0.45, 0.34, 0.38, 0.4}			
Receiver						

Signaling rate(range)	Sr		25.7825±100ppm		GBd	
Center Wavelength	λ_c	1320	1330	1340	nm	RT-AAZLC3-C(I)00
		1260	1270	1280	nm	RT-AAZL3C-C(I)00
Receiver Sensitivity (OMA)				-13	dBm	1
Receiver Reflectance	Rfl			-26	dBm	
Loss of Signal Assert	P _A	-30			dBm	
Loss of Signal De-assert	P _D			-13	dBm	
LOS Hysteresis	P _D - P _A	0.5			dB	

Note:

1. Hit ratio 5×10^{-5} .

Digital Diagnostic Memory Map

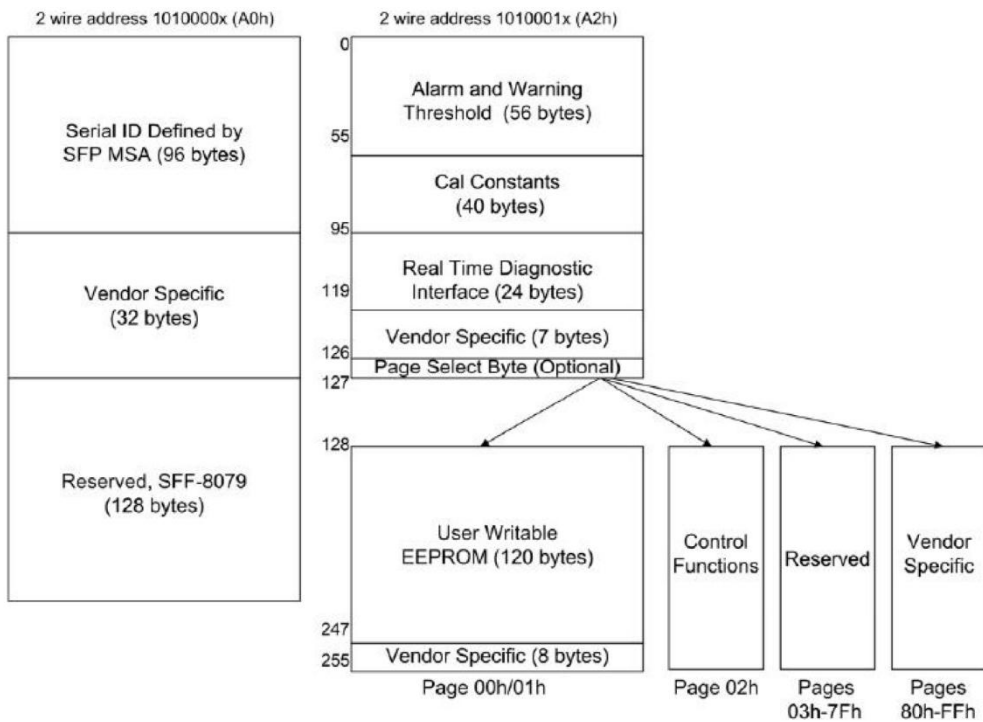

Digital Diagnostic Specifications

Parameter	Unit	Accuracy
Case Temperature	°C	±3
Supply Voltage	V	±3%
Tx Bias Current	mA	±10%
Tx Optical Power	dB	±3
Rx Optical Power	dB	±3

Electrical Interface Characteristics

Parameter	Symbol	Min	Type	Max	Unit	Ref.
Supply Voltage	V _{CC}	3.135	3.3	3.465	V	
Supply Current	I _{CC}			300	mA	Commercial
				360	mA	Industrial
Transmitter						
Input differential impedance	R _{in}		100			1
Differential data input swing	V _{in, pp}	100		800	mV	
Transmit Disable Voltage	V _D	2		V _{CC}	V	
Transmit Enable Voltage	V _{EN}	V _{ee}		V _{ee} +0.8	V	
Receiver						
Differential data output swing	V _{out, pp}	100		800	mV	2
LOS Fault	V _{LOS_fault}	2		V _{CC} HOST	V	3
LOS Normal	V _{LOS_norm}	V _{ee}		V _{ee} +0.8	V	3

Notes:

1. Connected directly to TX data input pins.AC coupling from pins into laser driver IC.
2. Into 100Ω differential termination.
3. LOS is an open collector output. Should be pulled up with 4.7kΩ – 10kΩ on the host board. Normal operation is logic 0; loss of signal is logic 1. Maximum pull-up voltage is 5.5V.

Recommended Interface Circuit

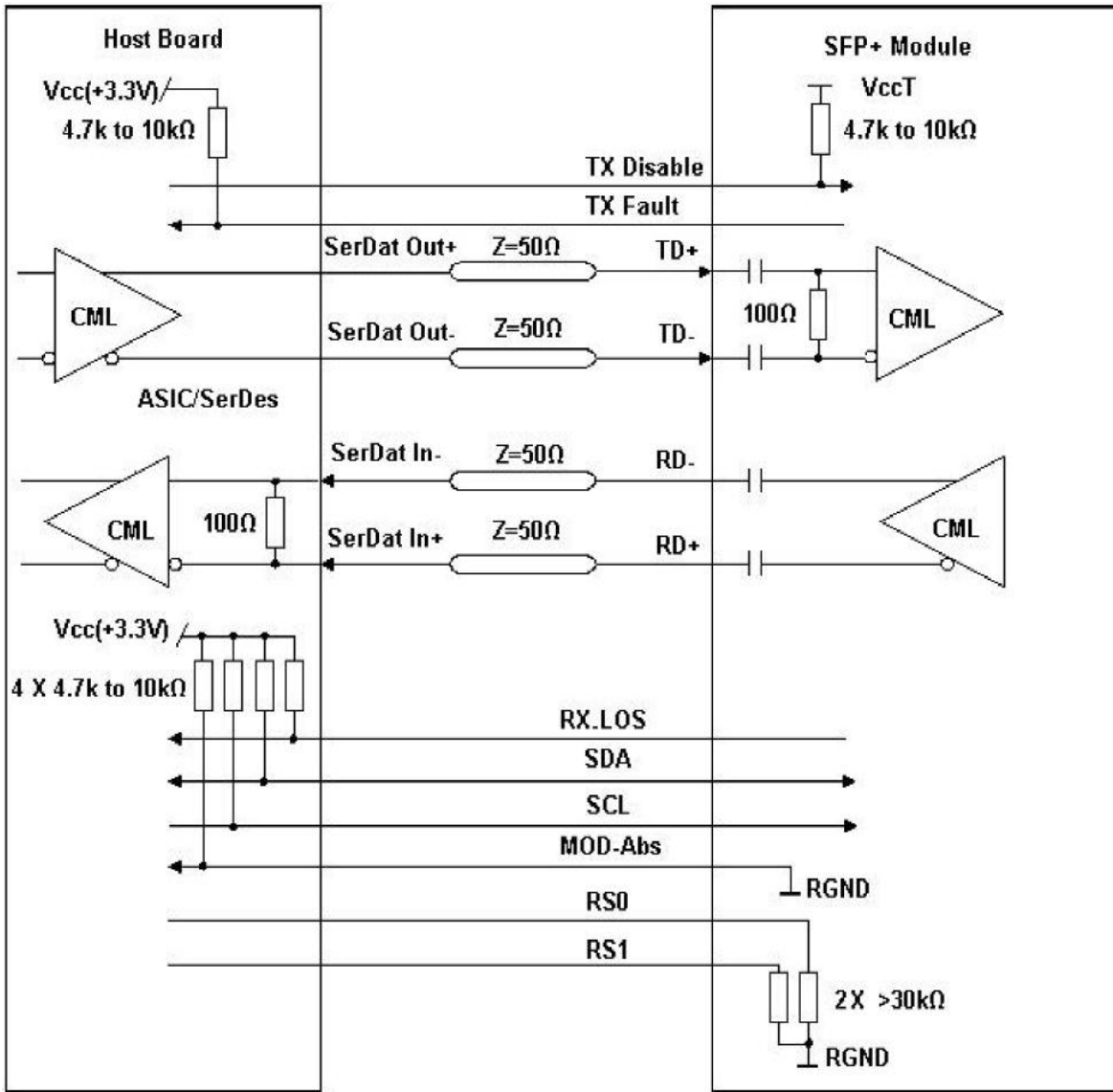

Mechanical Specifications (Unit: mm)

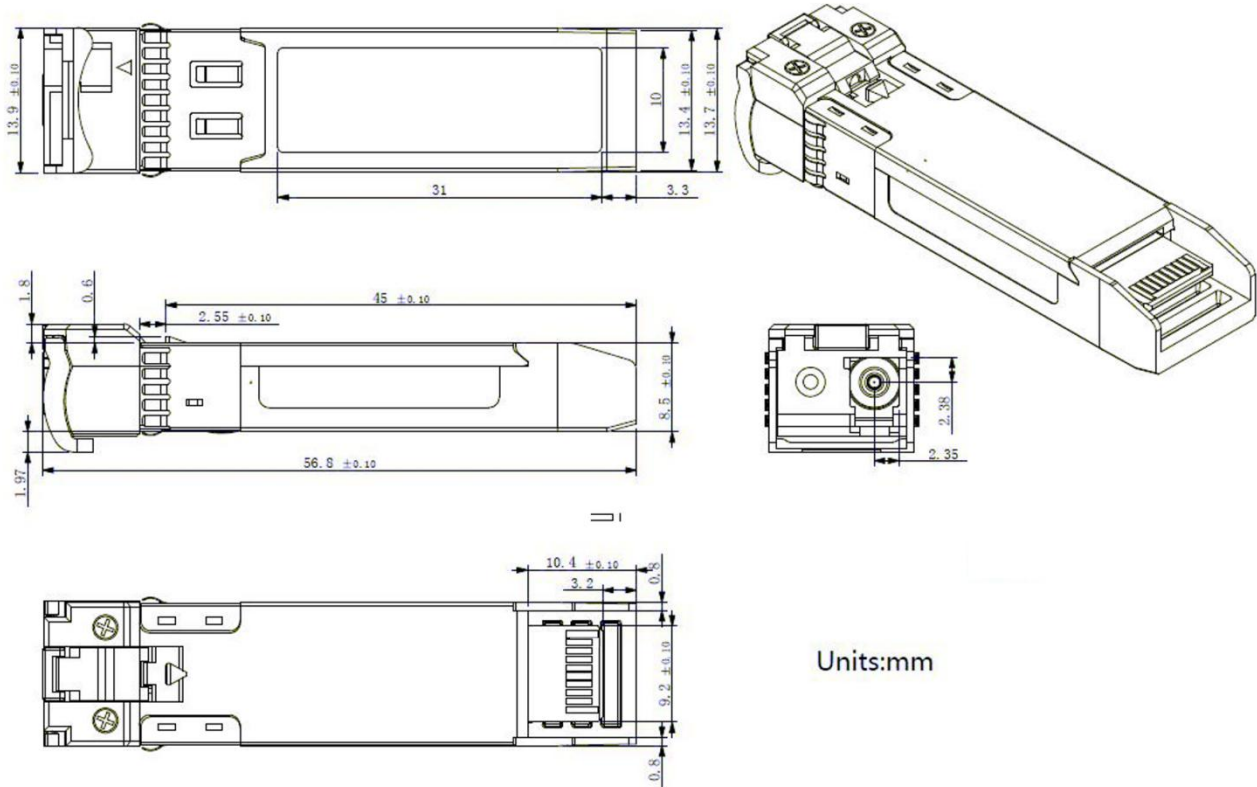

RT-AAZLXX-C(I)00

Contact Information

Wuhan RayOptekCO.,Ltd

Headquarter

Ⓧ Address:G3-201, New Energy Building, No.999 Gao Xin Road, Wuhan, Hubei, China

☎ Tel:+86-27-87106345

✉ Email:sales@rayoptek.com